

TIGERGRIP | GX 36-50

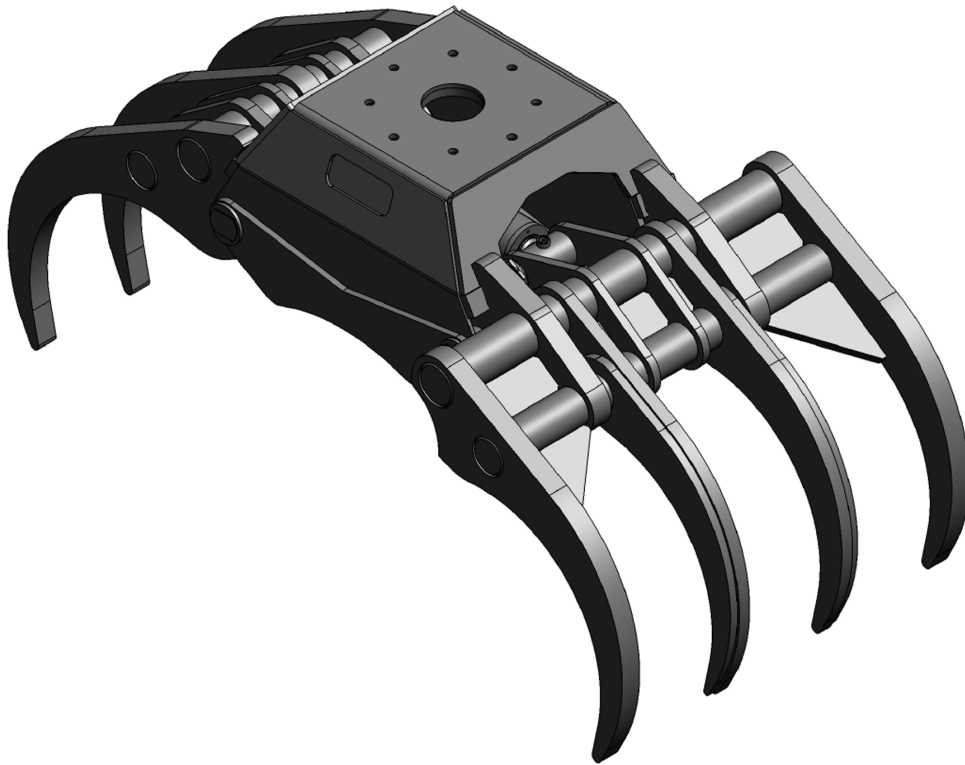

KEY FEATURES

- Heavy duty
- Double guide bars
- Optimized roll in/roll out properties
- High pressure cylinder with double piston rod seals
- High tensile wear resistant steel (400 HB)
- Extra reinforced body for rigid mounting - Excavator design

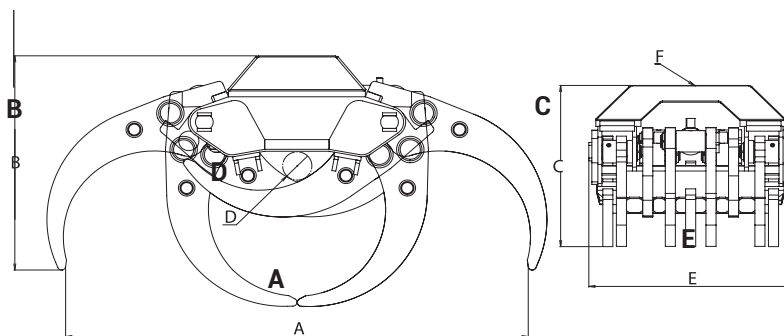

A	1690
B	954
C	672
D	120
E	1000

MODEL SPECIFICATIONS



GX 36-50

860

0,36

350

60

20,5

40

10

30

24

INTERMERCATO

High performance lift and load attachments for Forestry, Transport, Construction and Recycling.

